



CODING AND MARKING

Ax-Series Continuous InkJet Printers

Speed, precision, and reliable performance
in the most challenging environments.



Ax-Series printers

Designed to increase production efficiency

➤➤ Ax-Series printers are the winning choice for the most demanding production lines



Ax-Series printers offer an intuitive and reliable coding solution for a wide range of **marking requirements**, including **dates, traceability codes, variable data, and product branding**. They are fully compatible with Industry 4.0 standards.

The modern touchscreen user interface delivers an industry-leading user experience, while the **maintenance-free ink system** and i-Pulse printing technology ensure consistently high-quality codes, even in the most demanding production environments.

As a non-contact marking solution, the Ax-Series can print on a wide variety of surfaces and products—flat, round, irregular, or moving—supporting logos, 1D and 2D codes, multilingual text, and mixed fonts.

➤➤ Automatic code inspection

Ensure that every code leaving the factory is present, correct, and fully legible—while freeing up valuable operator time. With the R-Series, Domino's range of vision systems, you can automate code inspection to verify:

- Presence
- Positioning
- Readability



DOMINO INKS

➤ Domino supplies a comprehensive range of inks manufactured in accordance with GMP (Good Manufacturing Practice) and compliant with major global regulations for food packaging.

i-Pulse inks are designed to:

- Support a wide range of applications
- Ensure strong adhesion, even after demanding post-printing processes such as sterilization, thermal shock, and washing

Available in a broad range of colors, they deliver highly durable codes throughout the product's lifetime.

SMART INTEGRATION

➤ The growing demand for **accurate product traceability** increases the need for consistently correct and legible codes.

To ensure optimal code quality, the i-Pulse ink series is designed to work seamlessly with the R-Series, Domino's vision system, enabling automated inspection to:

- Automatically verify each code
- Eliminate manual inspections
- Reduce waste
- Prevent costly product recalls and brand damage

Domino Ax150i

The Domino Ax150i is the ideal solution for companies looking to expand production with a simple and reliable machine.

Compact and easy to operate, it delivers clear and legible codes even on small batches and standard applications. Perfectly suited to industrial environments, the Ax150i offers an excellent balance between performance, usability, and reliability.



Domino Ax350i

The Domino Ax350i continuous inkjet printer delivers consistent, high-quality codes, even in the most demanding industrial processes.

It ensures clear and well-defined marking on high-speed production lines, helping to reduce errors, waste, and operating costs. With IP66-rated sealed electronics and an IP55-rated cabinet, the Ax350i operates reliably in harsh industrial environments. A wide range of printheads and configurations makes the Ax350i a highly flexible solution that integrates easily into diverse production applications.

Domino Ax550i

The Domino Ax550i continuous inkjet industrial printer is the ideal solution for the most demanding production environments.

Its 316 stainless steel cabinet and sealed electronics provide maximum protection against dust, sugars, and chemicals, ensuring full waterproofing during line sanitation cycles.

Designed to maintain production continuity under extreme conditions, the Ax550i is the preferred choice for complex industrial and food processing applications.



»» I-Pulse technology

I-Pulse printhead technology represents a major advancement in continuous inkjet (CIJ) coding.



Industry
4.0
COMPLIANT

OPTIMIZED INK DROP FORMATION

- **I-Pulse** technology guarantees:
 - Improved code legibility and reliability, even at high speeds
 - 9-drop resolution (compared to traditional 7-drop systems)
 - Up to 24% reduction in ink consumption

I-PULSE HEADS

- To meet the specific requirements of different production environments, substrates, and data formats, Domino has developed a range of i-pulse printheads:
 - **40 µm and 50 µm**: ideal for high-resolution 2D and alphanumeric codes on components of various shapes and sizes
 - **60 µm and 75 µm**: the most versatile choice for a wide range of industrial applications
 - Cylindrical stainless steel variant: hygienic and robust, with a smooth extruded sheath, designed for harsh environments and frequent washdowns
 - Duo printhead: dual-jet technology enabling up to 10 lines of text or double the printing speed
 - Horizontal, vertical, and angled printheads (H90, V90): for easy installation on compact lines and narrow products



Domino inks comply with all relevant national and international regulations.

The solvent bases supplied by Domino are free from drug precursors, in accordance with Regulation (EC) No. 1277/2005.



➤ **Areas of use:**

➤ **Food & Beverage**

- Maximum flexibility and operational continuity on production lines
- Seamless integration with filling machines and line systems
- Traceability coding
- Resistance to washing and sanitizing processes
- Industry 4.0 connectivity



➤ **Industrial**

- Marking large, clearly visible codes on extruded materials
- Printing MRC and identification codes on electronic components
- Printing very small text on cables and profiles
- Using a wide range of inks for high-impact coding



➤ **Pharma, Cosmetics & Personal Care**

- Regulatory and validation process expertise
- Integration with leading vision and inspection systems
- Complete validation documentation
- Regulation-compliant inks for reliable and consistent coding



DISCOVER NIMAX DIGITAL INNOVATIONS



Line Strategy is the application that gives you full control of your production line from a single workstation:

- Connects machines of any brand on the line;
- Reduces human error and enables centralized production control;
- Provides real-time reports on production performance;
- Reduces costs and streamlines tooling, control, and maintenance processes;
- Interfaces with company MES and ERP systems.



MyNimax Service Portal is your central platform for managing your Nimax machine fleet:

- AI-powered support with ai.max, available 24/7, for fast issue resolution;
- Integrated e-shop for easy ordering of consumables and spare parts;
- Unlimited remote assistance from our technical support team;
- Complete service and maintenance history.

Technical Specifications

Printer specifications	Ax150i	Ax350i				Ax550i			
Nozzles	60µm	40µm	50µm	60µm	75µm	40µm	50µm	60µm	75µm
Speed – 1 line, 5-point characters (m/s)*	5,1	5,3	5,9	7,1	6,8	5,3	5,9	7,1	6,8
Deposited print drop size (mm)**	0,31	0,23	0,26	0,31	0,40	0,23	0,26	0,31	0,40
Print height (single print head)	Up to 32 points / 20 mm								
Print height (Duo)	N/A	Up to 64 points / 40 mm							
Supported formats	Text, graphics, 1D/2D codes (Unicode)								
Printer features									
User interface	7" touchscreen				7" / 10.4" touchscreen				
Conduit length	3 m				3 m / 6 m				
Head type	Straight				Straight, H90, V90, RS, Duo				
Software	QuickStep 3								
Communication ports	Cabinet USB port (x1); Ethernet RJ45 port (x1)								
Printer status monitoring	4-stage signal / 3-stage alarm								
"Cartridge replacement (ink and make-up)"	Automatic recognition, takes 20 seconds, no line stoppage								
ITM replacement	Requires less than 10 minutes of line downtime								
Maintenance interval***	Typically 12 months								
Cabinet material	304 stainless steel + nylon door	304 stainless steel, IP55 / IP66 electronics				316 stainless steel, IP55 / electronics IP66			
Consumables									
Available inks	Wide range of black and colored inks, including food-grade options, for eggshells, color toning, and UV-fluorescent								
Ink cartridge volume	825 ml								
Make-up volume	1200 ml								
Optional hardware packages****									
Extended communication package	N/A	Additional USB, control port				Additional USB, control port			
RS232 package	RS232 port (x1)								
GPIO package	4 inputs / 4 outputs (x1)								
Extended I/O package	N/A	12 inputs / 6 outputs (x1)							
Optional performance packages*****									
Operator assistance package	N/A	Label templates, barcode scanning for text insertion in messages, access management							
Green package	N/A	Make-up reduction up to 20% and programmable automatic shutdown for lower consumption							
Continuous printing package	N/A	Quick screens, simplified label creation, and high-speed print formats (ST & HS rasters)							
Advanced security package	N/A	Advanced security management with customizable permissions for each user							

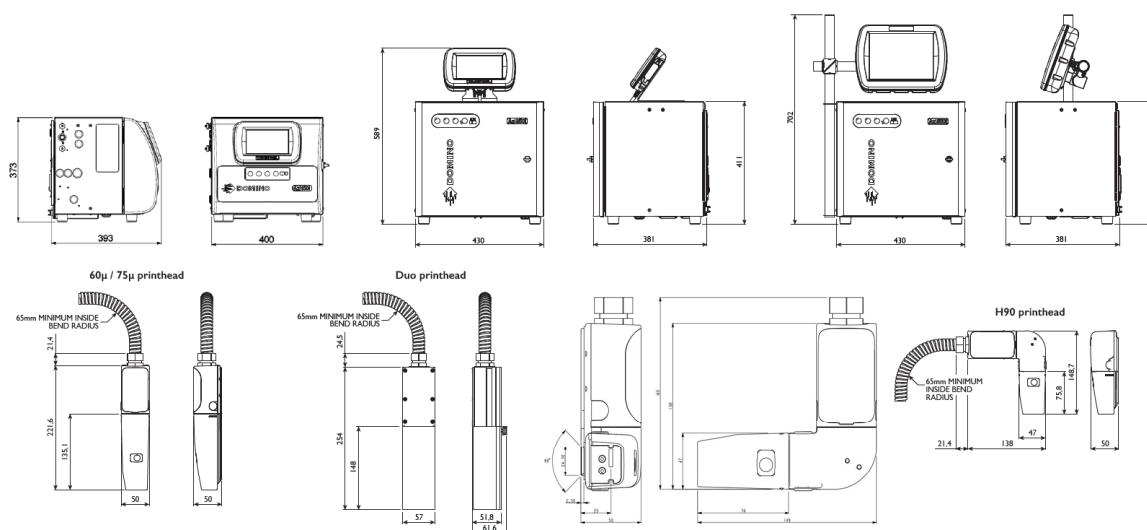

*Declared speed calculated using the following characters per inch: 75 µm = 8 characters, 60 µm = 10 characters, 50 µm and 40 µm = 14 characters.

**The size of the drop may vary depending on the surface.

*** Depends on the type of ink and the version of ITM used.

****This product works exclusively with Domino electronic hardware and uses security systems to prevent the use of unauthorized components; the hardware may be updated periodically to ensure its effectiveness.

*****Specifications subject to change depending on the market.

DISCOVER MORE

